

**Preparation**  
**By electrical**  
**Engineer**

**Azad**  
**Faraydoon**  
**H.Amin**

**SOLAR  
LIGHTING  
SYSTEMS**

**WHITE LED BASED  
SOLAR STREET LIGHTING  
SYSTEMS**

# INTRODUCTION

Electric Street Lights are big consumers of energy, costing millions to cities and municipalities around the world. Solar Street Lights were initially used mainly in Third World countries, in remote areas or where electricity is not always available or supply unreliable. Today's solar technology has evolved and solar projects are appearing in developed as well as developing countries.

Solar energy source provides pollution-free, self-contained, reliable, quiet, long-term, maintenance-free, and year-round continuous and unlimited operation at moderate costs .

The Solar LED Street Light System converts the sun's energy into electricity and stores it to provide illumination from dusk to dawn. The system includes the power generator (panel/s), storage (battery) and management (controller) as well as the LED light, pole and weather-proof housing. Luminaries utilize High Power LED's with superior thermal management design which are switched on by a timer switch built into the system.

# Chapter 1

## 1-1 SYSTEM OPERATION:

The system converts the sun's energy into electricity and stores it to provide 8-12 hours of light plus 2-3 days worth of backup energy in case of cloudy days.

Activation Switch On/Off: A microprocessor automates the functions of the system automatically activates from sunset to sunrise; has a timer, regulating the hours the light stays on; also regulates the battery, preventing overcharging and protecting against discharging. Optional wireless on/off .

### Solar LED Street Lights



LED street lights are energy-saving products using high power LEDs as the light source. LEDs are very energy efficient since their consumption is much less than conventional lamps. LEDs can also run for up to 50,000 hrs.

## Solar Street Lights (LED)



### ١-٢ Solar system benefits:

- ❖ Easy installation no wiring required.
- ❖ Installing and moving is easy no more waiting for the utility company! -Proven technology.
- ❖ Vandal theft-resistant components and hardware.
- ❖ All parts are corrosion resistant.
- ❖ Low installation cost.
- ❖ Easily and quickly deployed in almost any location.
- ❖ NO wiring run from the grid.
- ❖ NO cuts through existing roads, sidewalks or landscaping.
- ❖ NO Maintenance.
- ❖ NO Utility bill.
- ❖ Maintenance Free Batteries!
- ❖ Better Color Rendition & Nighttime Visibility.
- ❖ No Warm-Up or Cold Start Problems.

## 1-3 DEFINITION

Light Emitting Diode (LED) is a device which emits light when an electric current passes through it. A LED based solar street lighting system aims at providing solar electricity for operating LED lights for specified hours of operation per day.

The broad performance specifications of a White Light Emitting Diode (LED) light source based solar street lighting system are given below.



## LAMP STYLES

## 1-4 LED FEATURES

- High Luminous Efficiency
- Revolutionary Photometric Design.
- Unique Integrated Lens and Lampshade Design.
- Creative Design of the Radiator and Lamp holder Integration.
- High Color Index
- No UV or IR, Impact Resistance, Shock-proof.
- Long Life, up to 50,000 hours.
- Tremendous Energy Saving, save energy 50%~80% than the conventional sodium and mercury lamps.
- Work under Low-voltage and Low-heat, Safe and Reliable.
- Perfect Combination with Solar Energy.

## 1-6 BROAD PERFORMANCE PARAMETERS

Light Source:	White Light Emitting Diode (W-LED) .
Light Out put:	White colour, minimum 10 lux when measured from a height of about 2 metre and illuminated over an area of at least 2 metre diameter. Higher light output will be preferred.
Mounting of light :	Minimum 2 metre pole Mounted .
PV Module:	20 Wp under STC, measured at 16.5 V – Vload Module Voc minimum of 21 V .
Battery:	Tubular Lead acid , 12 V- 20 AH @ C/10, Max DoD 50% .
Electronics:	Min 80% total efficiency
Average duty cycle:	Dusk to dawn
Autonomy :	7days (Minimum 24 operating hours per permissible discharge) .

## Solar Power – Block Diagram

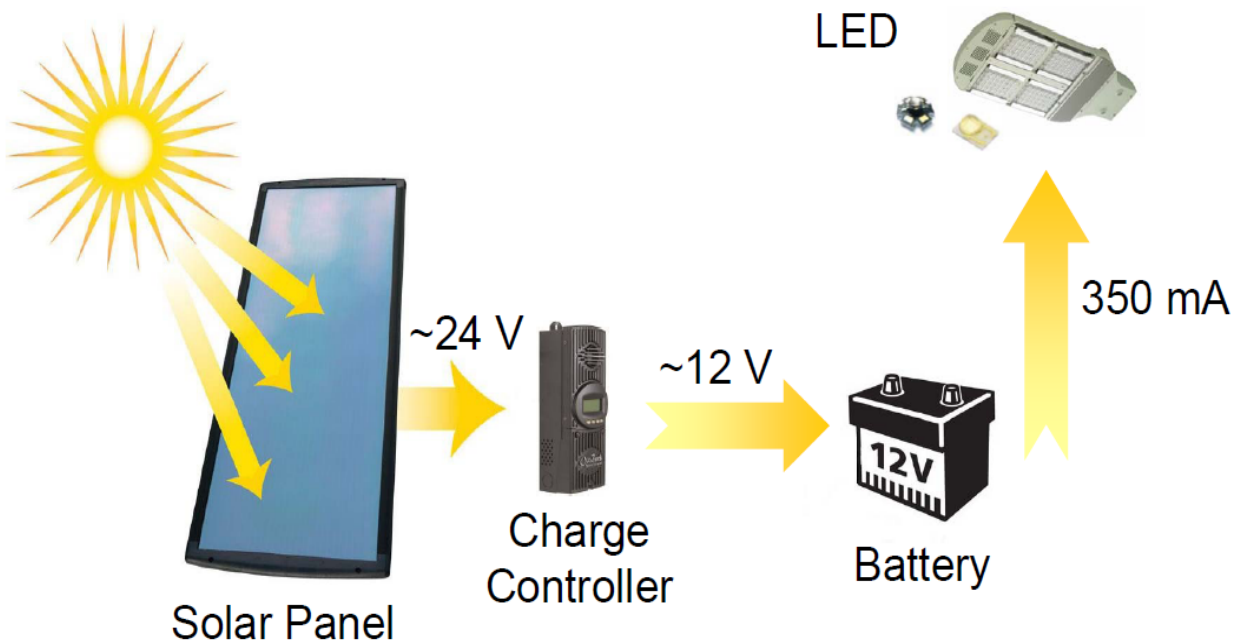

## 1-6 Solar Lighting Applications:-

- Area Lighting.
- Airport Lighting.
- Hospital Parking.
- Parking Lot lighting.
- Highway Roadway Lighting.
- Street lighting.
- Security Light.
- Highway and ramp lighting.
- Bridge lighting, Under Pass lighting.
- Residential, Industrial, Commercial lighting.
- Luminaires produce high quality white light @ 5000K color temperature which greatly enhances the nighttime visibility, color rendition & Scotopic (nighttime) visibility of the human eye.



## Chapter 2

### 2-1 DUTY CYCLE

The LED solar street lighting system should be designed to operate for dusk to dawn, under average daily insolation of 5.0 kWh /sq.m. on a horizontal surface.

### 2-2 LIGHT SOURCE

1. The light source will be of white LED type. Single lamp or multiple lamps can be used. Wider view angles of a minimum of 120° and above preferred. The luminous performance of LEDs used should not be less than 100 lumen/watt. The colour temperature of white LEDs used in the system should be in the range of 5000 K – 7000 K. Use of LEDs which emit ultraviolet light is not permitted.

2. The light output from the white LED light source should be constant through out the duty cycle.

3. The lamps should be housed in an assembly suitable for outdoor use.

4. The make, model number, country of origin and technical characteristics of white LEDs used in the lighting system must be furnished to the test centers and to the buyers. In absence of this data the solar lantern may not be tested by the test center.



## **५-३ BATTERY**

(i) Tubular Lead acid battery. Battery should conform to latest BIS standards or international standards. A copy of the test certificate for the battery (including its make, country of origin and model number) used in the system should be provided to the test center.

(ii) At least १० % of the rated capacity of the battery should be between fully charged & load cut off conditions.

## **५-४ ELECTRONICS**

(i) The total electronic efficiency should be at least १० %.

(ii) Electronics should operate at १५ V and should have temperature compensation for proper charging of the battery through out the year.

(iii) The light output should remain constant with variations in the battery voltages.

(iv) Necessary lengths of wires / cables, switches suitable for DC use and fuses should be provided.

## **५-० PV MODULES**

१. The PV modules based on crystalline silicon (single or multi) solar cells or thin films may be used. In all cases a test report is required from authorized test center. The module must be manufactured by a company, which has obtained a valid test certificate for module qualification as per prevailing IEC or BIS standards for any of the modules manufactured by that company. A copy of the IEC certificate must be submitted to the test agency at the time of submission of the samples for testing of the system, failing which the sample may not be tested.

२. The power out put of the PV module must be reported under standard test conditions (STC) at ११.६ Volt loading voltage. I\_V curve of the sample module should be submitted to the test center at the time of system qualification testing.

३. The open circuit voltage of the PV modules under STC should be at least २१.० Volts.

४. The terminal box on the module should have a provision for opening for replacing the cable, if required.

०. A strip containing the following details should be laminated inside the module so as to be clearly visible from the front side:

a) Name of the Manufacturer or distinctive Logo

b) Model or Type No.

c) Serial No.

d) Year of make

## **५-१ ELECTRONIC PROTECTIONS**

१. The system should have protection against battery overcharge and deep discharge conditions. The numerical values of the cut off limits must be specified, while submitting the samples for the testing purposes.

२. Fuses should be provided to protect against short circuit conditions.

३. A blocking diode should be provided as part of the electronics, to prevent reverse flow of current through the PV module(s), in case such a diode is not provided with the PV module.

४. Full protection against open circuit, accidental short circuit and reverse polarity should be provided.

## **५-२ MECHANICAL COMPONENTS**

(i) Metallic frame structure (with corrosion resistance paint) to be fixed on the roof of the house to hold the SPV module. The frame structure should have provision to adjust its angle of inclination to the horizontal between  $0^\circ$  and  $45^\circ$ , so that it can be installed at the specified tilt angle.

(ii) It should be possible to mount the light source on a metallic arm attached to the pole. The metallic arm for holding the light assembly should be extended at least 1.0 metres from the pole and set at a suitable angle to maximize uniform illumination of desired level over the specified area.

(iii) A vented metallic / plastic box with acid proof corrosion resistance paint for housing the storage battery outdoors should be provided.

## **५-३ OTHER FEATURES**

(i) The system should be provided with २ LED indicators: a green light to indicate charging in progress and a red LED to indicate deep discharge condition of the battery. The green LED should glow only when the battery is actually being charged.

(ii) There will be a Name Plate on the system body which will give:

(a) Name of the Manufacturer or Distinctive Logo.

(b) Model Number.

(c) Serial Number.

(d) Year of manufacture

## **५-४ QUALITY AND WARRANTY**

(i) Components and parts used in White LED solar street lighting systems should conform to the latest BIS / international specifications, wherever such specifications are available and applicable. A copy of the test report / certificate stating conformity of BIS / international

standards must be submitted to the test centre.

(ii) The PV module will be warranted for a minimum period of 10 years from the date of supply and the complete White LED solar street lighting system (including the battery) will be warranted for a period of at least 5 years from the date of supply.

(iii) The original manufacturers of white LED based solar home lighting system are required to provide to the test center a detailed report on the tests performance by them and the actually measured values of PV module, electronics, LEDs and battery and other related parameters, as per MNRE specifications. Mere mention of compliance to MNRE specifications is not acceptable and such samples may not be tested by the Test center.

The test center will refer to the measured values provided by the manufacturer in the test report issued by the test center.

#### **2-10 DOCUMENTATION**

(i) An Operation, Instruction and Maintenance Manual, in English and the local language, should be provided with the solar street lighting system.

#### **2-11 The following minimum details must be provided in the Manual:**

(a) About Photovoltaics .

(b) About White LED solar street lighting system - its components and expected performance .

(c) About PV module. In case of imported modules it is mandatory to provide a copy of the international product qualification certificate to the test centre.

(d) About White LED Lights. The make, model number, country of origin and technical characteristics of LEDs should be stated in the product data sheet and furnished to the test centres .

(e) About battery and electronics used .

(f) Clear instructions about mounting of PV module.

(g) About charging and significance of indicators.

(h) DO's and DON'T's,

(i) Clear instructions on regular maintenance and trouble shooting of solar street lighting system.

(j) Name and address of the person or service center to be contacted in case of failure or complaint.

# Chapter 3

## Disposition of aiming points in intersections

### 3.1 Intersections in right angle with two illuminated roadways

Two cases must be distinguished for this type of intersections: whenever motor traffic on roadways is not canalized (Figs. 1 to 4), and whenever motor traffic on only one of the roadways is canalized by means of small directional traffic islands (Fig. 5).

When motor traffic on roadways is not canalized, the problem must be tackled by combining installations recommended for each type of lighting (one-sided, staggered, double row, two-sided, etc.), as represented in Figs (1 to 4).

Aiming points drawn in intersections in white serve as the basis for installing the rest.

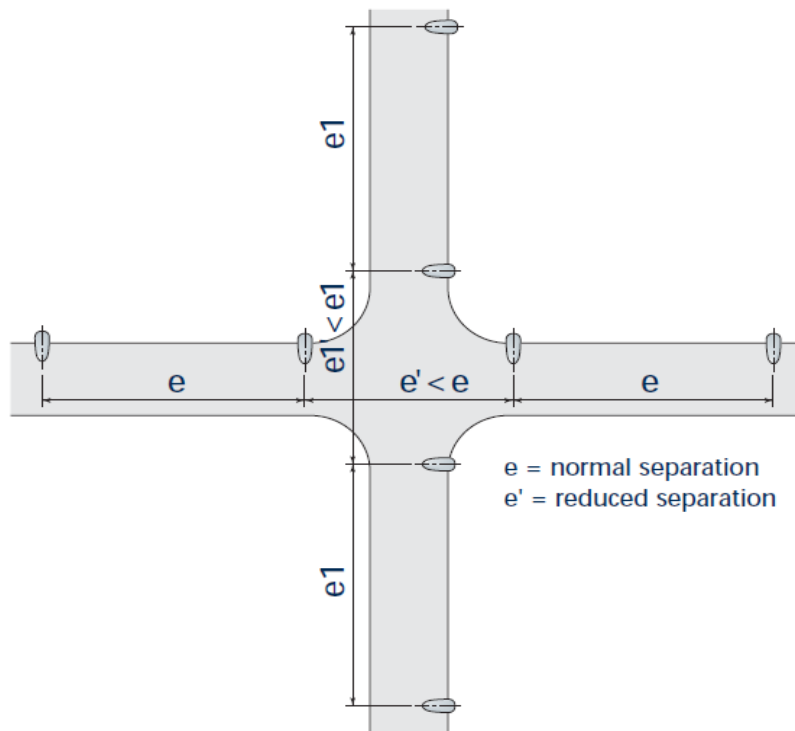

Right angle intersection: Recommended installation on two roadways with one-sided lighting

Fig (1)

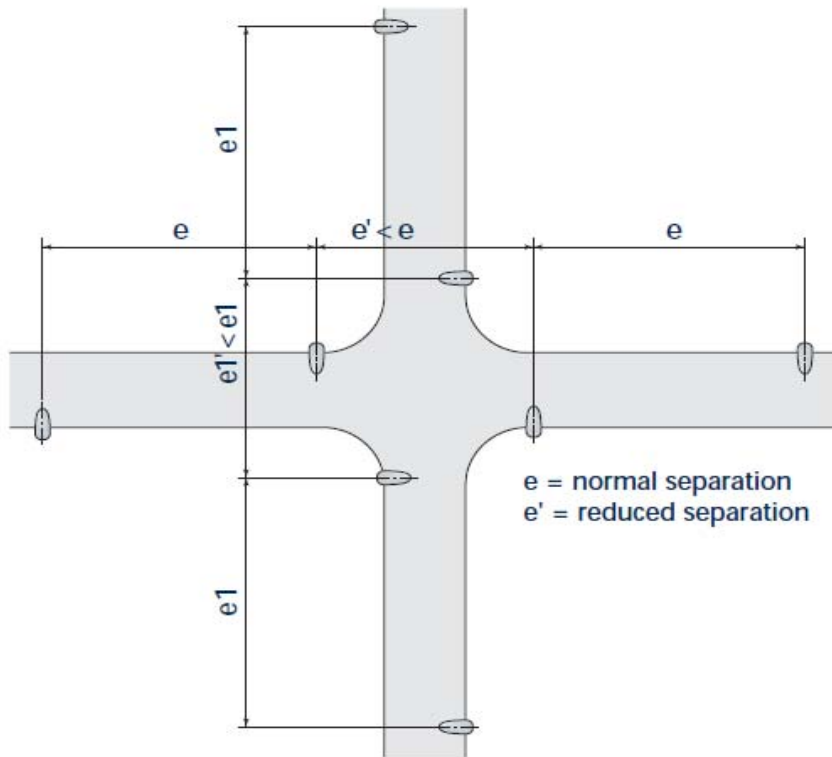

Right angle intersection: Recommended installation on two roadways with staggered lighting

Fig (۲)

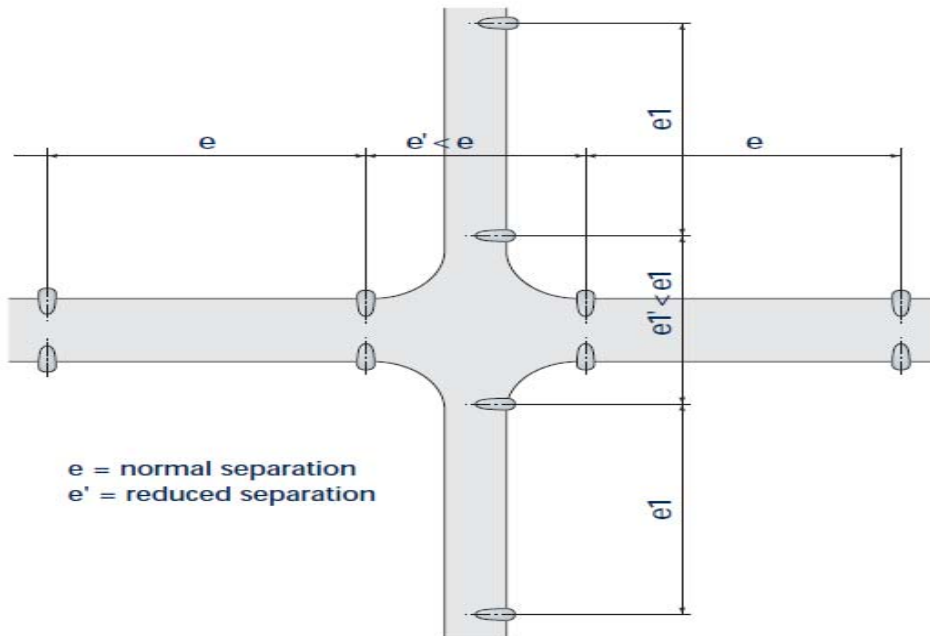

Right angle intersection: Recommended installation on two roadways with one- sided and two- sided lighting

Fig (۳)

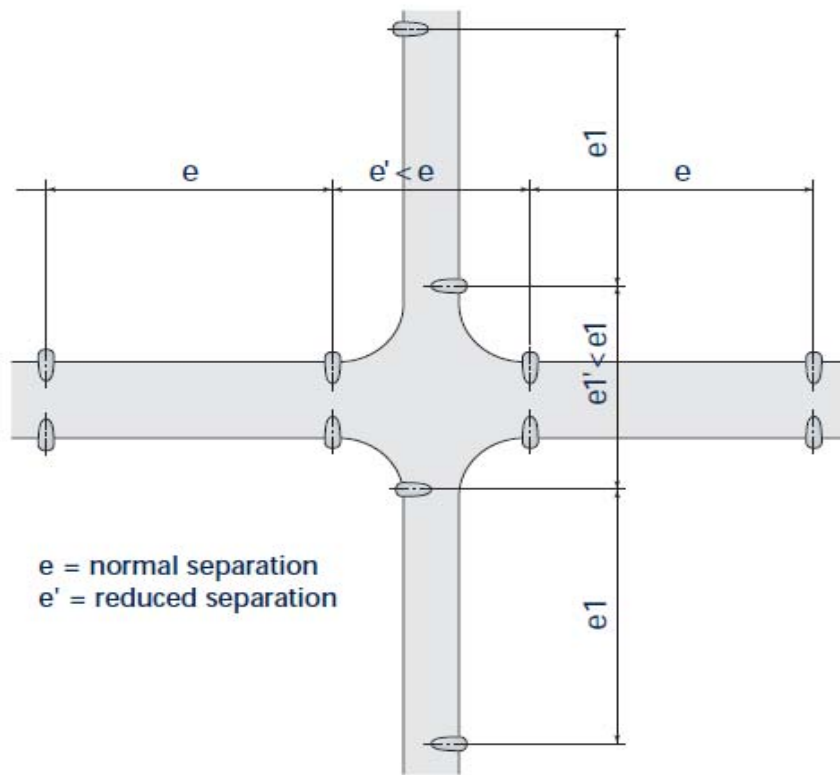

Right angle intersection: Recommended installation on roadways with staggered and two- sided lighting

Fig (ε)

In the second case, when motor traffic in one of the roadways is canalized by means of small directional traffic islands whereas, traffic is not in the other, (Fig. ο), the installation of aiming points must begin with the roadway provided with traffic islands, which will be studied separately. The installation of aiming points will begin from the intersection,

Reducing the separation between these and continuing with the roadway with canalized traffic, adopting any of the adequate installation systems (one- sided, staggered, double row, two- sided, etc.).

The origin of locating aiming points for roadway lighting wherever traffic is not canalized by means of traffic islands will be also tackled at the intersection, adjusting aiming points as established for the other roadway, and continuing with an adequate placing of aiming points bearing in mind the roadway characteristics (one- sided, staggered, double row, two- sided, etc.).

Eventually, lighting in the center of the intersection may be reinforced by installing more powerful aiming points, by Adopting more powerful lamps or installing two luminaires in every aiming point or support.

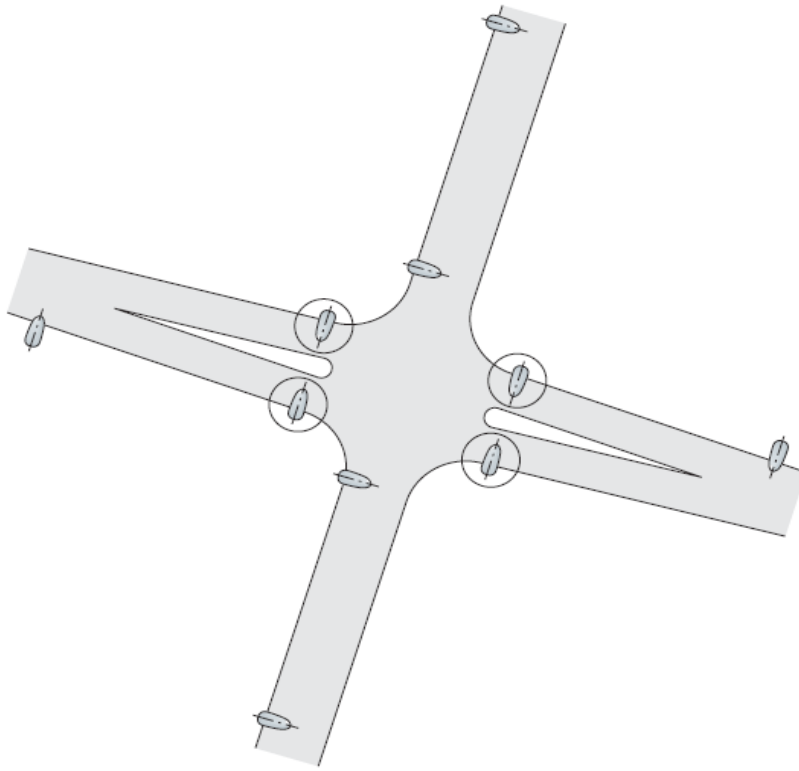

"X"- shaped intersection: It may turn useful to provide circled aiming points with more power

Fig (٥)

### ٣.٢ "T"- shaped intersections between two illuminated and partially canalized roadways

This type of intersections (Fig. ٦) establishes an installation of aiming points recommended so that users who arrive from the merging roadway are able to see an illuminated background ahead of them. This is not the only possible solution, though. Depending on local conditions, it may be possible to reduce the number of aiming points, using others of a higher potency and height installation (Fig. ٧).

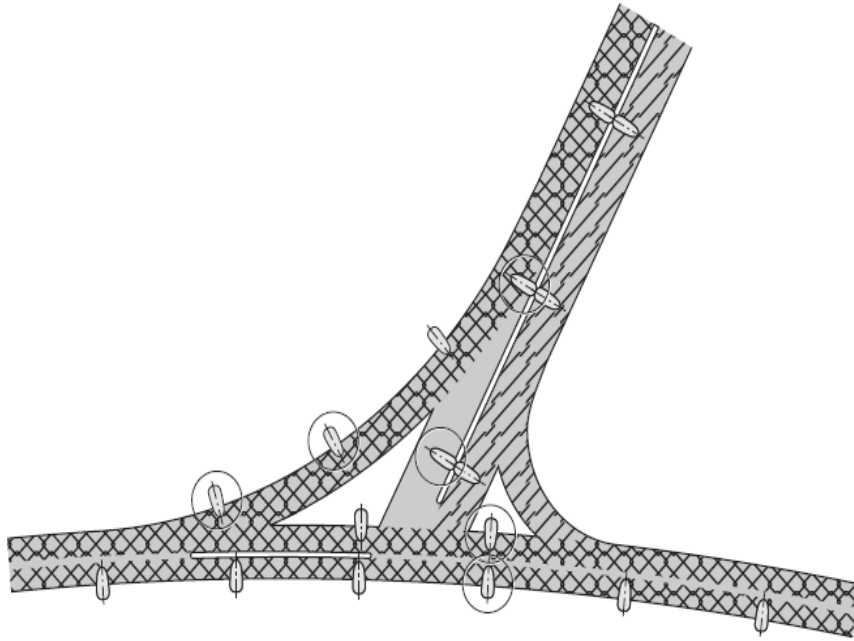

"T"- shaped intersection: Installation example. Double lined areas represent the visual guidance effect that must be provided by lighting. It may turn useful to provide circled aiming points with more power.

Fig (٦)

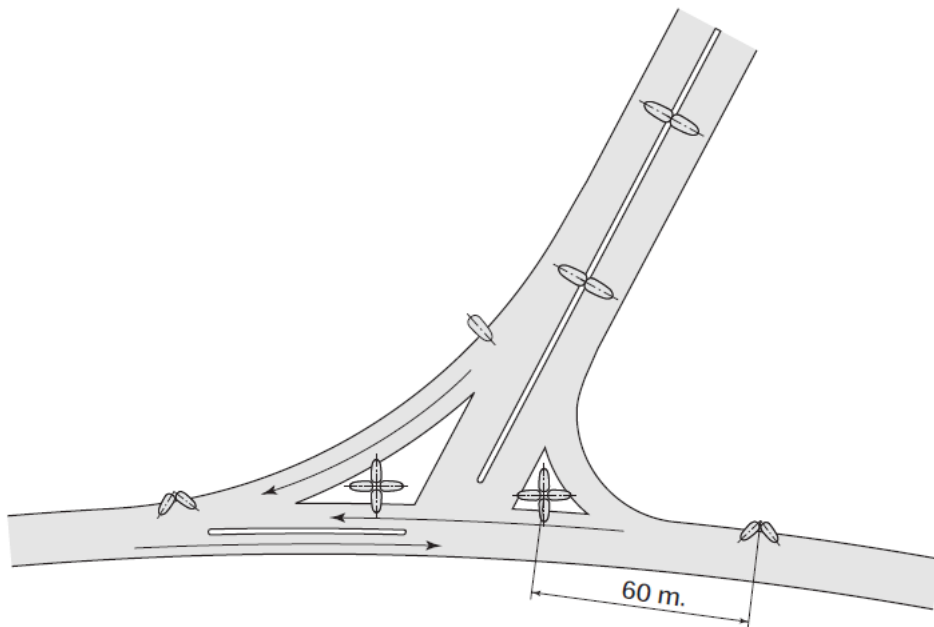

"T" – shaped intersection: Installation example with aiming points of more power and of height supports than those of fig (٦ to ٧) . Aiming point of ١٨m, with ٤ luminaire . Aiming point of ١٨m , with ٢ luminaires .Aiming point of ١٢m , with ١ luminaire. Aiming Point of ١٢m, with ٢ luminaires .

Fig (٧)



### ۳.۳ "Y" or "T"- shaped intersections between two roadways totally canalized

In the proximity of such intersections, generally both traffic directions for vehicles are separated by large directional traffic islands, along which the layout of aiming points is one- sided (Fig. ۸). Likewise, more powerful and aiming points of a greater height may be placed (Fig. ۹).

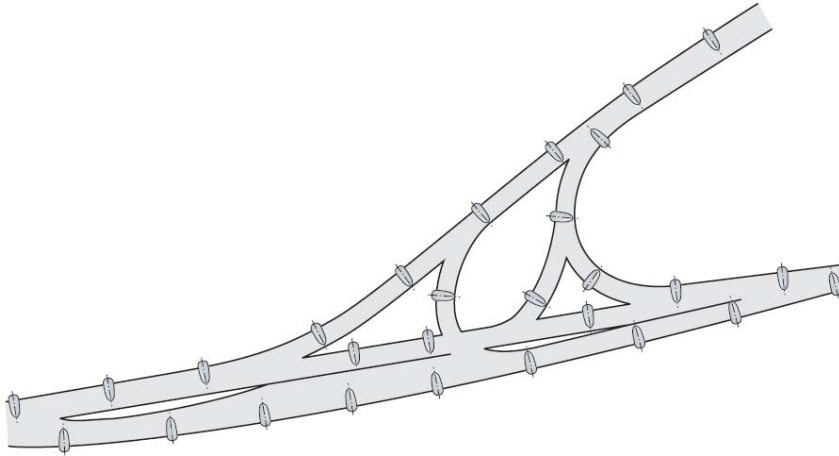

"Y" or "T"- shaped intersection: Example of a one- sided installation on two important roadways totally canalized by means of traffic islands

Fig (۸)

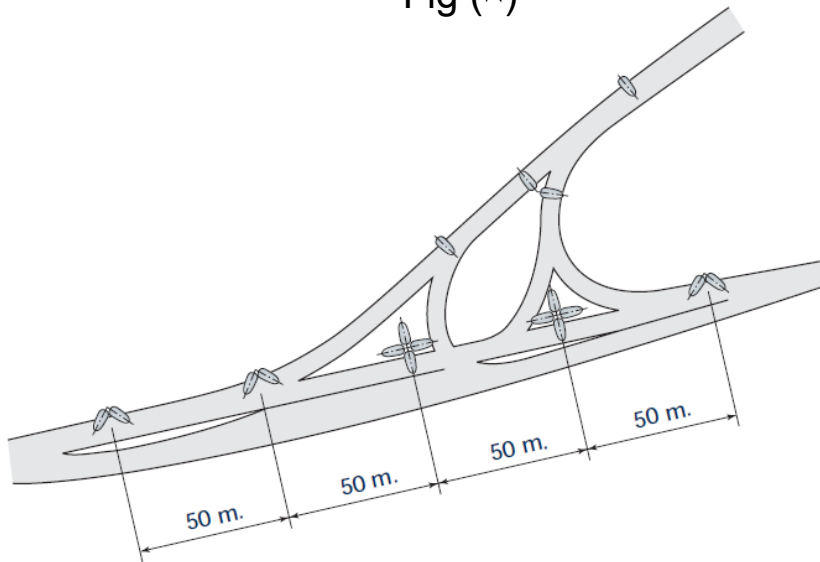

"Y" or "T"- shaped intersection: Example of a one sided installation With aiming points of more power and height than those of fig ( ۸ to ۹ ).

Fig (۹)

### ۳.۴ Vegetation

Understanding and cooperation between vegetation and lighting is required so that neither interferes with the job or function performed by the other.

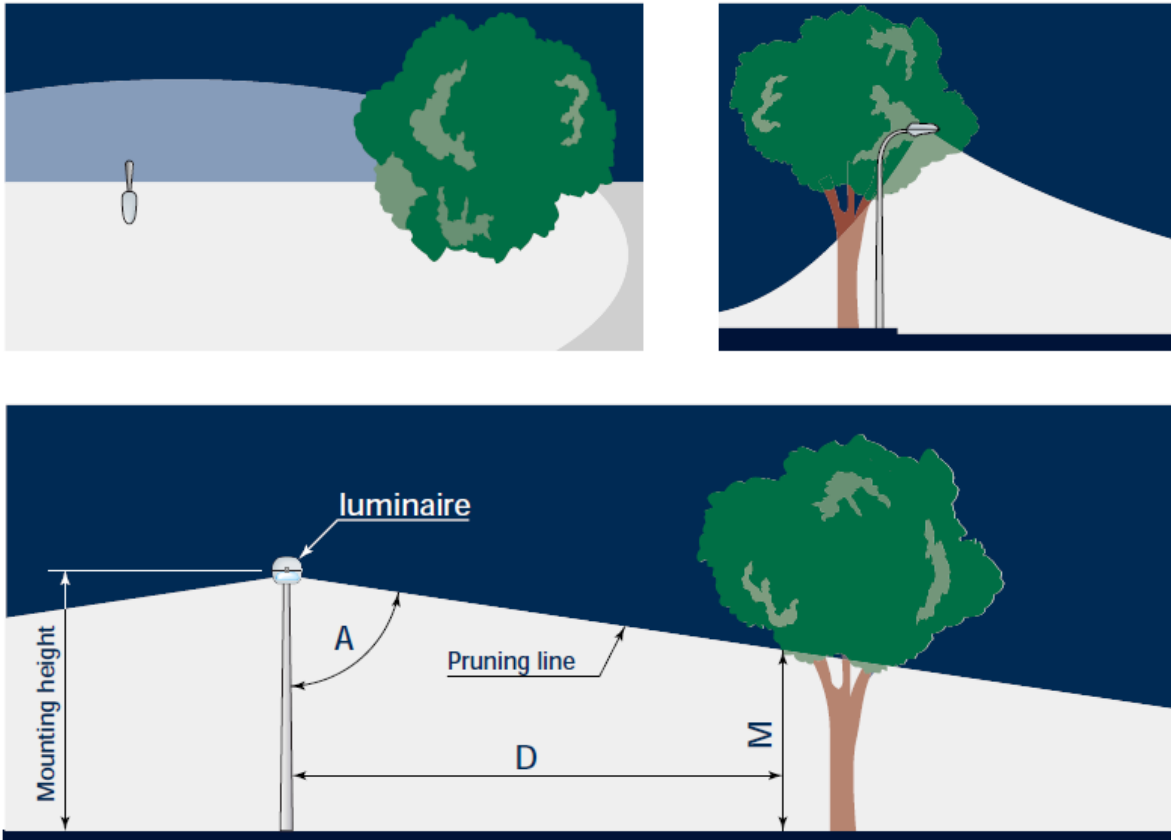

Fig(۱۰)

Pruning line angle "A"	Tree pruning height
70°	$M = 0.36 D$
75°	$M = 0.26 D$
80°	$M = 0.17 D$

The selection of the type of shrub or tree must be based on those which leave enough free space for lighting with minimum interference between both of them. These selections may include trees with stylized, spherical or normal forms. In most cases, a good pruning service may solve any problem between trees and road lighting.

It must be highlighted that even in installations with a great mounting height, it is not necessary to prune all trees up to the luminaire height. It is only necessary to prune those branches which fall below the useful luminous beam (Fig. ۱۰). Leafiness of trees located between the luminaire and the objects, may serve the purpose of trimming and distinguishing silhouettes in an intentioned way. At the same time, it helps to reduce luminaire direct glare on possible observers or drivers. This advantage is particularly important in roads with local traffic and residential areas, where relatively high inter-distances, together with high potencies and angles approaching the horizontal are required.

**Electrical Engineer**  
**Azad Faraydoon H.Amin**

۲۵ / ۹ / ۲۰۱۱

# INDEX

pag	Subject
۱	Introduction.
۲	<b>Chapter ۱</b>
	۱-۱ System operation.
۳	۱-۲ Solar system benefits.
۴	۱-۳ Definition. ۱-۴ Led features.
۵	۱-۵ Broad performance parameters. ۱-۶ Solar Lighting Applications.
	<b>Chapter ۲</b>
۶	۲-۱ Duty cycle. ۲-۲ Light source.
۷	۲-۳ Battery. ۲-۴ Electronics. ۲-۵ PV Module.
۸	۲-۶ Electronic protections. ۲-۷ Mechanical components. ۲-۸ Other features. ۲-۹ Quality and warranty.
۹	۲-۱۰ Documentation. ۲-۱۱ The following minimum details must be provided in the Manual.
	<b>Chapter ۳</b>
۱۰	Disposition of aiming points in intersections ۳.۱ Intersections in right angle with two illuminated roadways.
۱۳	۳.۲ "T"- shaped intersections between two illuminated and partially canalized roadways.
۱۵	۳.۳ "Y" or "T"- shaped intersections between two roadways totally canalized.
۱۶	۳.۴ Vegetation.
۱۷	References